

## SXXCXXX-XXXN-D

### Constant Current Driver

Model: SXXCXXX-XXXN-D

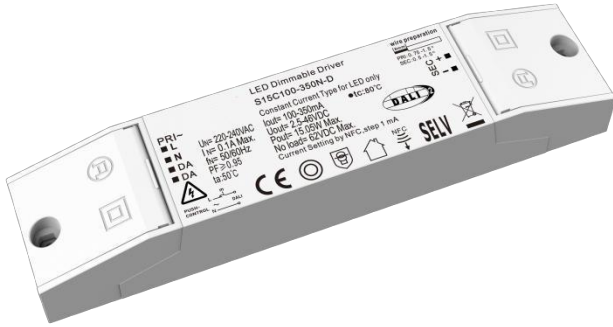

Model	Output Current	Input Current	Input Power	Output Power Range	PF	Efficiency	Output Voltage	No load Voltage
S15C100-350N-D	100-350mA	≤0.1A	21W	0.25-15.05W	≥0.95	86%	2.5-46V	62V
S23C100-700N-D	100-700mA	≤0.16A	29W	0.25-23W	≥0.95	87%	2.5-46V	62V
S36C150-900N-D	150-900mA	≤0.25A	42W	0.375-36W	≥0.95	88%	2.5-50V	65V

\* Test result @230V, 50Hz, Max Full Load

### 1. Parameters

Category	Item	Technical Norm
Features	Output Type	Constant Current
	Current Setting	Near field communication (NFC)
	Output Features	Isolation
	IP Grade	IP20
	Insulation Class	Class II
Input	Rated Input Voltage	220-240VAC
	Range of Input Voltage	198-264VAC
	Range of DC Input Voltage	220-280VDC
	Frequency	50/60Hz, Range:47-63Hz
	Input Current	≤0.1A max@15W; ≤0.16A max@23W; ≤0.25A max@36W
	Input Power	≤21W max@15W; ≤29W max@23W; ≤42W max@36W;
	Power Factor	≥0.95 (230VAC , full load)
	THD	≤ 10% (230VAC , full load) @ S36C150-900N-D ≤ 15% (230VAC , full load) @ S15C100-350N-D 、 S23C100-700N-D
	Standby Power Consumption	≤0.5W @230VAC
Output	Output Voltage@15W	2.5-46VDC@ 100-300mA 2.5-43VDC@ 301-350mA
	Output Voltage@23W	2.5-46VDC@100-500mA,2.5-41VDC@501-550mA, 2.5-38VDC@551-600mA,2.5-35VDC@601-650mA, 2.5-32VDC@ 651-700mA
	Output Voltage@36W	2.5-50VDC@150-700mA,2.5-48VDC@701-750mA, 2.5-45VDC@751-800mA,2.5-42VDC@801-850mA, 2.5-39VDC@ 851-900mA
	No Load Voltage (Uout)	62VDC Max@15W 23W 65VDC Max@36W
	Output Current @15W	100-350mA (by NFC setting)

**SXXCXXX-XXXN-D**

	Output Current @23W	100-700mA (by NFC setting)
	Output Current @36W	150-900mA (by NFC setting)
	Max. Output Power @15W	15.05W
	Max. Output Power @23W	23W
	Max. Output Power @36W	36W
	Efficiency	≥86% @15W(230VAC@max full load) ≥87% @23W (230VAC@max full load) ≥88% @23W (230VAC@max full load)
	Output LF current ripple(< 120 Hz)	±5% (Imax-Imin) / (Imax+Imin) (230VAC@full load)
	Current Accuracy	±5%@ 301-900mA, ±10%@ 100-300mA
	Output PstLM (at full load)	≤ 1
	Output SVM (at full load)	≤0.4
	Starting Time (AC mode)	≤0.7S (230VAC)
Control Method	NFC current setting	The output current can be set within the total value range in 1-mA-steps. Output current is mean value.Setting is by KGP's software APP/APK/PC with FEIG equipment or mobile phone.
Protection	Short Circuit Protection	Auto Recovery
	Overload Protection	Auto Recovery (not be hot swap)
	No-load Protection	Auto Recovery
	Insulation voltage	3000V 5mA 60S between P-S, 1500V 5mA 60S between P-E
	Insulation resistance	>100M ohm @ 500VDC
	Leakage current	< 700pA, I/P to O/P or I/P to PE @230V input
Environment	Ta/ Operation Temperature	-20 ...+50°C
	Ts/ Storage Temperature	-20 ...+85°C
	Tc/ Enclosure Temperature	85°C@15W & 23W; 90°C@36W
	Humidity	10%.... 90%RH
	Atmosphere	86- 108KPa
Construction	Connection Method	Push-in Terminal
	Installation	Build-in & Independent
	PRI Wire preparation	0.5- 1.5 <sup>□</sup> / 8-10mm
	SEC Wire preparation	0.5- 1.5 <sup>□</sup> / 8-10mm
	Dimension @Independent	138.7*31*21.5mm (L*W*H) Independent @15W & 23W 118.7*31*21.5mm (L*W*H) Built in @15W & 23W 163.7*31*21.5mm (L*W*H) Independent @36W 143.7*31*21.5mm (L*W*H) Built in @36W
Standards	Certification	CE
	Safety Standards	EN 61347-1:2015/A1:2021 EN 61347-2-13:2014/A1:2017 EN IEC 62384:2020 EN 62493:2015 AS61347.2.13:2018 AS/NZS61347.1:2016 Inc A1 BS EN 61347-1:2015/A1:2021 BS EN 61347-2-13:2014/A1:2017

### SXXCXXX-XXXN-D

		BS EN 62493:2015 BS EN IEC 62384:2020
	EMC Standards	EN IEC 55015:2019 EN IEC 55015:2019/A11:2020 EN IEC 61000-3-2:2019/A1:2021 EN 61000-3-3:2013/A2:2021 EN 61547:2009
	Performance	EN62384:2020
	Surge	L-N:1kV
Others	RoHS	2011/65/EU
	Audible Noise	<20dB @ 30cm distance, 16dB background
	Life Time	50000h @Ta / Tc
	Warranty	5years , F.R. < 10000ppm
Remark: 1.All Parameters, if not specified, are measured at 230VAC/50Hz and 25 °C ambient temperature. 2.LED Driver is a component of the luminaires, Luminaires and wire layout will affect the EMC, please check the EMC with end products again.		

## 2. Connected quantities of different current Breaker

TYPE	Connected quantities of different current Breaker@15W,23W						Input Voltage	Inrush Current	Time
	current (A)	10	13	16	20	25			
	Installation wire diameter	1.5mm <sup>2</sup>	2.5mm <sup>2</sup>	2.5mm <sup>2</sup>	4mm <sup>2</sup>	4mm <sup>2</sup>			
TYPE B		15	20	24	30	38	@230VAC	40	300us
TYPE C		24	31	38	48	60			
TYPE D		38	50	61	77	96			

TYPE	Connected quantities of different current Breaker@36W						Input Voltage	Inrush Current	Time
	current (A)	10	13	16	20	25			
	Installation wire diameter	1.5mm <sup>2</sup>	2.5mm <sup>2</sup>	2.5mm <sup>2</sup>	4mm <sup>2</sup>	4mm <sup>2</sup>			
TYPE B		11	14	17	22	27	@230VAC	55	300us
TYPE C		17	23	28	35	44			
TYPE D		28	36	45	56	70			

SXXCXXX-XXXN-D

3. Label

**KGP** LED Dimmable Driver  
**S15C100-350N-D**  
 Constant Current Type for LED only  
 •tc:80°C

UN= 220-240VAC  
 I<sub>N</sub>= 0.1A Max.  
 f<sub>N</sub>= 50/60Hz  
 PF≥0.95  
 ta:50°C

wire preparation  
 18mm  
 PRI:0.75-1.5"  
 SEC:0.5-1.5"

■ L  
 ■ N  
 ■ DA  
 ■ DA  
 PRI~

CE, DALI 2, SELV, NFC, PUSH-CONTROL, DALI

**KGP** LED Dimmable Driver  
**S23C100-700N-D**  
 Constant Current Type for LED only  
 •tc:85°C

UN= 220-240VAC  
 I<sub>N</sub>= 0.16A Max.  
 f<sub>N</sub>= 50/60Hz  
 PF≥0.95  
 ta:50°C

wire preparation  
 18mm  
 PRI:0.75-1.5"  
 SEC:0.5-1.5"

■ L  
 ■ N  
 ■ DA  
 ■ DA  
 PRI~

CE, DALI 2, SELV, NFC, PUSH-CONTROL, DALI

**KGP** LED Dimmable Driver  
**S36C150-900N-D**  
 Constant Current Type for LED only  
 •tc:90°C

UN= 220-240VAC  
 I<sub>N</sub>= 0.25A Max.  
 f<sub>N</sub>= 50/60Hz  
 PF≥0.95  
 ta:50°C

wire preparation  
 18mm  
 PRI:0.75-1.5"  
 SEC:0.5-1.5"

■ L  
 ■ N  
 ■ DA  
 ■ DA  
 PRI~

CE, DALI 2, SELV, NFC, PUSH-CONTROL, DALI

4. Graph

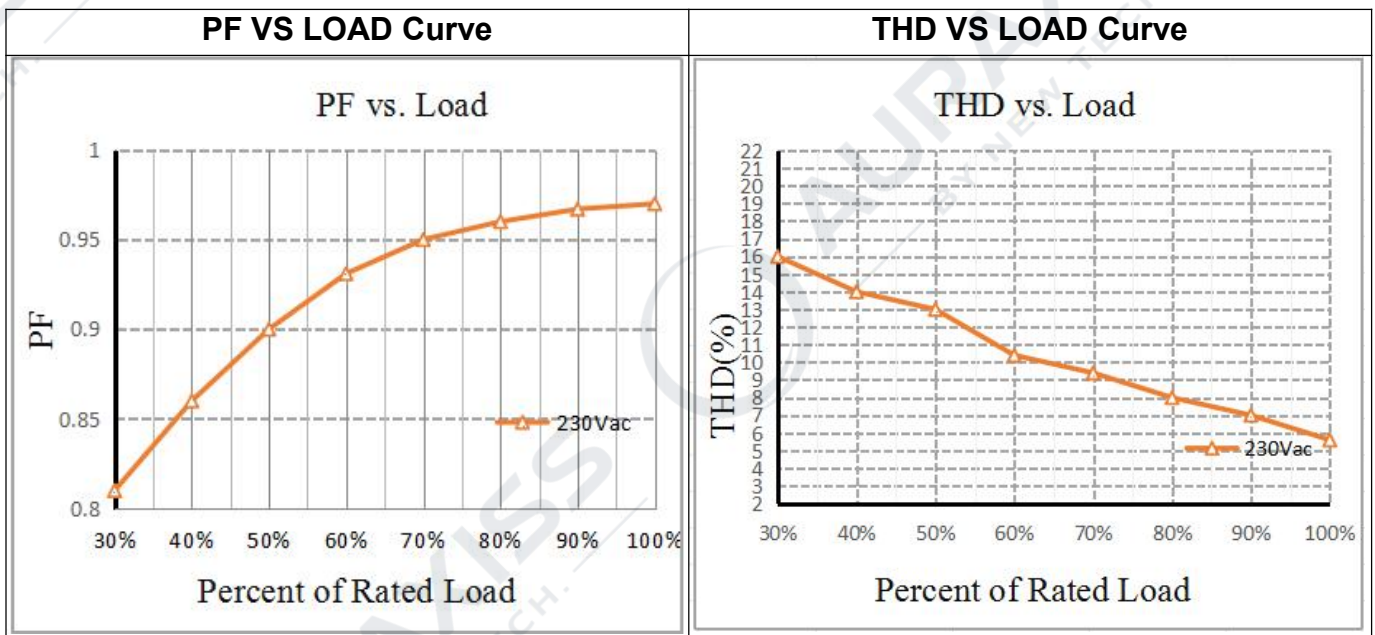

**SXXCXXX-XXXN-D**

**Efficiency VS LOAD Curve**

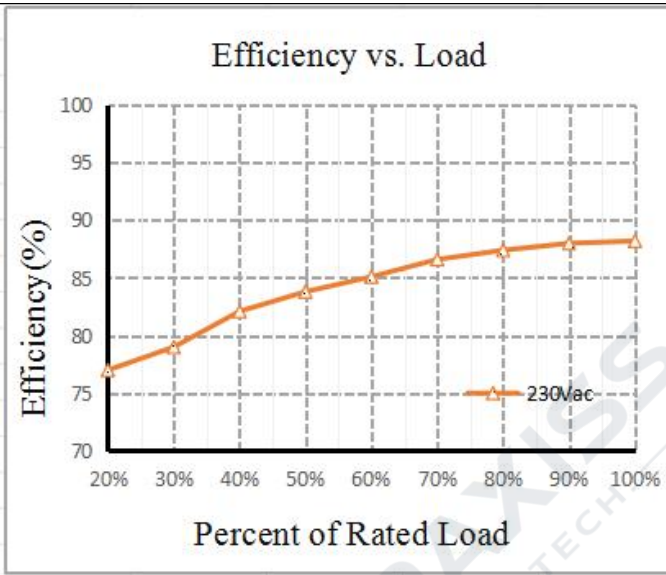

**Output Power Window @15w100-350**

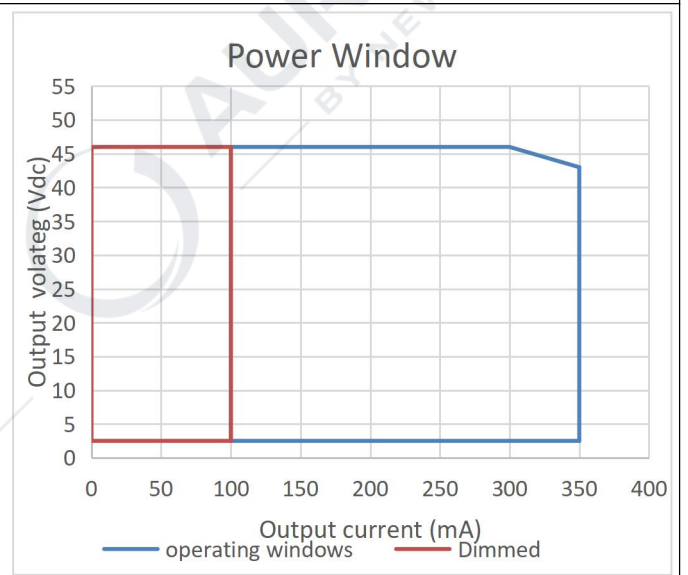

**Output Power Window @23w100-700**

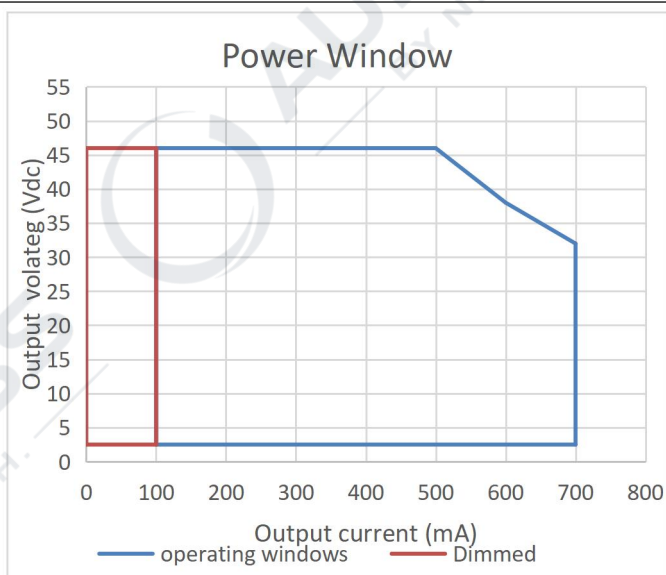

**Output Power Window @36w150-900**

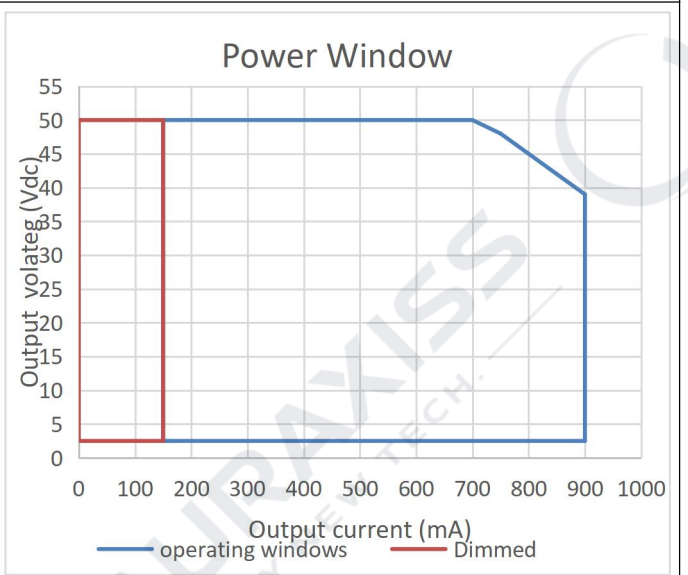

**SXXCXXX-XXXN-D**

**5. Lifetime curve**

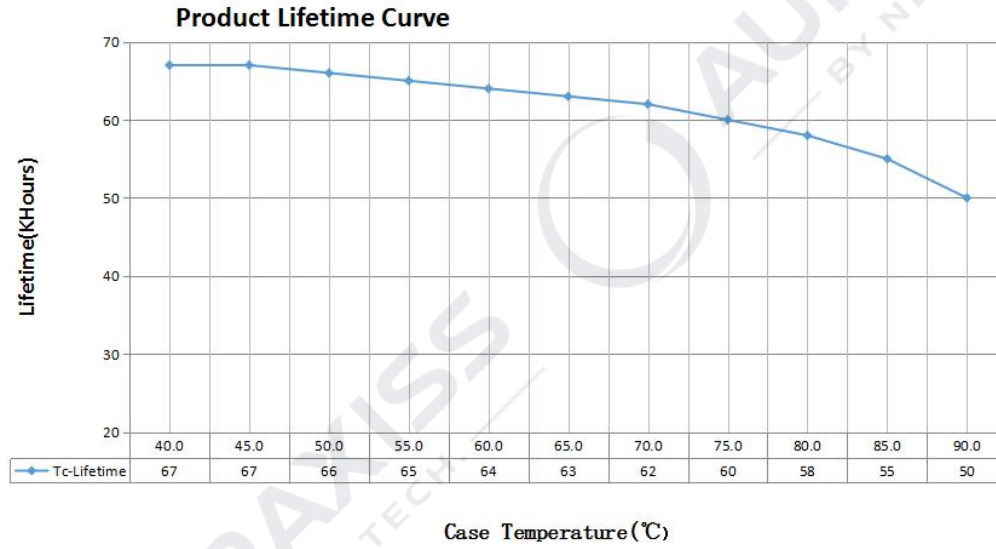

**6. Dimension ( Unit: mm)**

Independent type:@15W & 23W

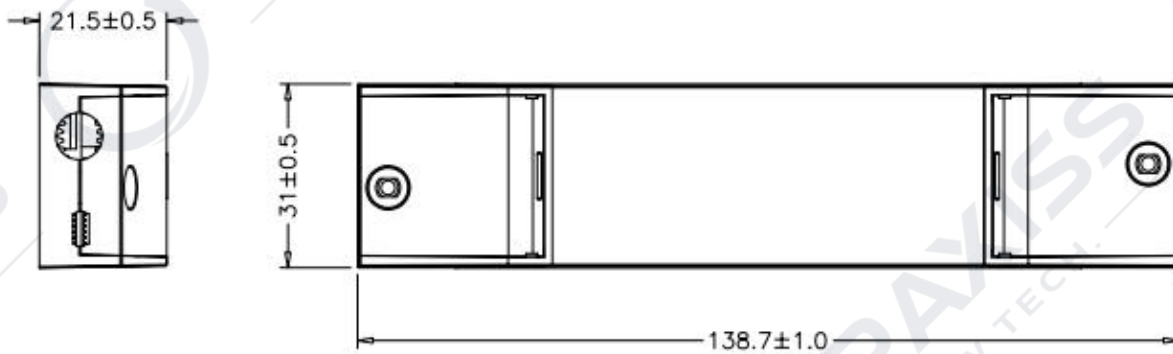

Built in type:@15W & 23W

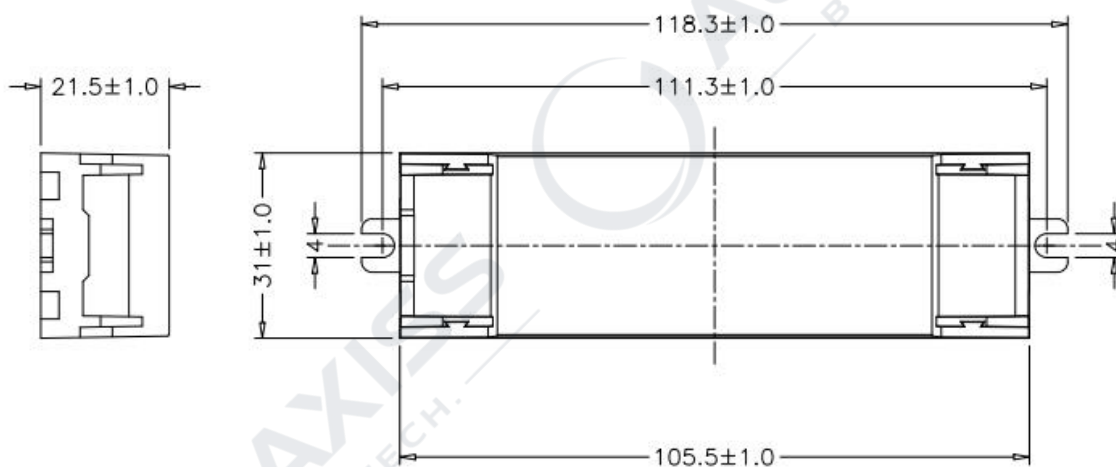

### SXXCXXX-XXXN-D

Independent type:@36W

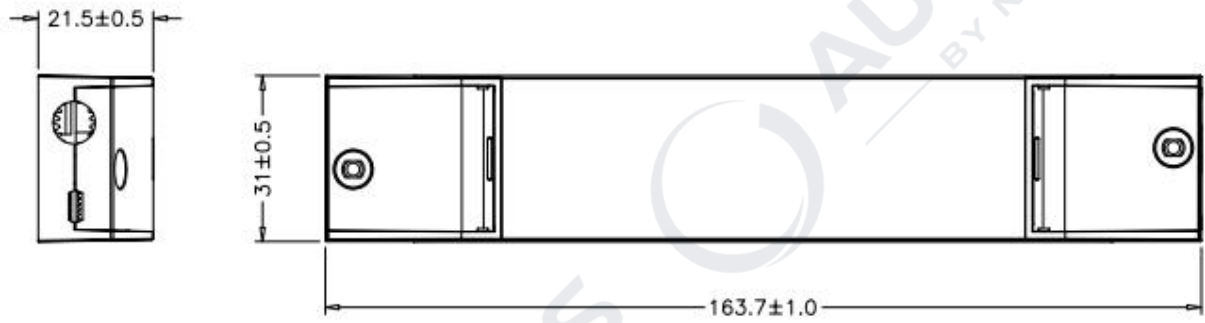

Built in type:@36W

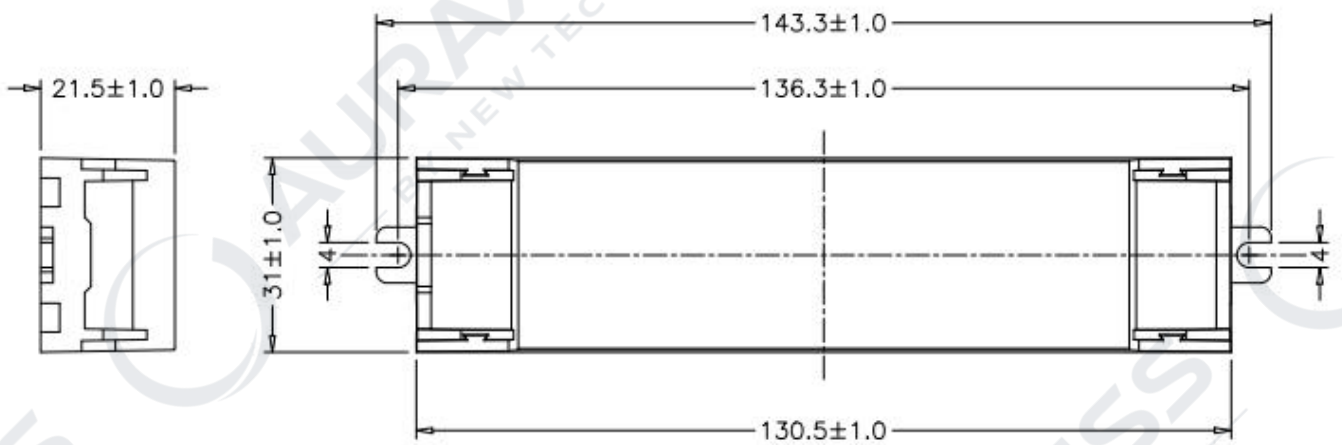

### 7. Wiring Diagram

220-240 V  
0/50/60 Hz



## SXXCXXX-XXXN-D

### 8. Packing information

Independent

Carton L*W*H(mm)	Pcs/Carton	Net weight/ Pcs(kg) Independent	Net weight/Carton(kg)	Gross weight/ Carton(kg)
370*185*245	100 @15W	0.067	6.7	7.26
370*185*245	100 @23W	0.089	8.9	9.46
370*185*245	100 @36W	0.129	12.9	13.46

### 9. NFC Reader (optional)

Feature:

Easily on-line read a output current from a driver or write a new current data to a driver throughout KGP



NFC reader within few seconds.



**Remark:**Please scan the QR code with your browse.

## 10. Perform operations on IOS APP



- 1) Search for "KGP NFC" software in Apple App Store and install the app (this version is the official version, the value can be read only after the product parameters are fully confirmed, if you need to read and write in the development stage, you need to share the permission code with Hong Yinghui company through 1OS mailbox to download the beta version)

- 2) Open the software and click the "NFC" button in the lower left corner to enter the NFC read and write page



- 3) Click the "read" button in the lower left corner to enter the NFC scan

## SXXCXXX-XXXN-D



- 4) Take SC42W300-1050CG-6 DT8-NFC as an example. After successful scanning, enter the interface as shown below, which will display the product name and output current of this section -> Click the "Edit" button in the lower right corner to enter the editing page

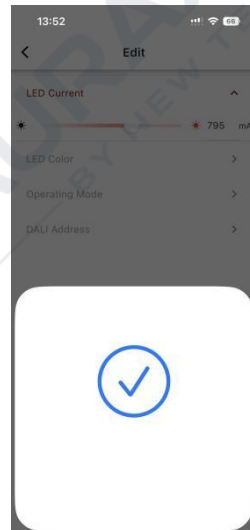
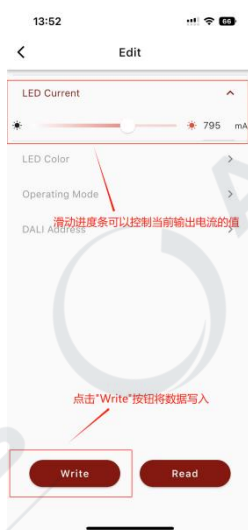
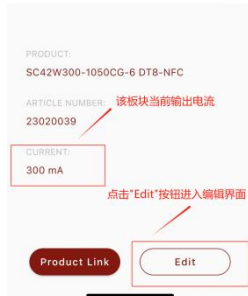

- 5) The progress bar under the sliding LED Current can control the value of the output current of the plate 1 channel, generally after the sliding is completed it will automatically enter the page of burning data, and the "✓" sign will be displayed if the burning is successful. (Below is the content of the beta version)

## 11. Wiring instructions

- All connections must be kept as short as possible to ensure good EMI behaviour
- Mains leads should be kept apart from LED Driver and other leads (ideally 5 – 10 cm distance)
- Advice the maximum length of output wires is 3 m
- Secondary switching is not permitted (Except for constant voltage)
- Incorrect wiring can damage LED modules.
- The wiring must be protected against short circuits to earth (sharp edged metals parts, metal cable clips, louver, etc.)

SXXCXXX-XXXN-D

## 12. REVISION HISTORY

DATE	REV	REMARK
2024-01-18	V1.0	Initial release.