



4-partition Human Motion Detection Sensor KG/F-CMPS.1

Functional Description

- Daytime and nighttime configuration mode
- Constant Lumen Output (CLO)
- Master and slave operation mode
- Supports sensor partitioning function, and can configure 4 partition functions.
- Full-automatic and Semi-automatic modes
- Logical function
- Scene Group Function
- 4channels movement control function can be configured

Characteristics

- 24GHz human presence sensing function
- Human body presence/movement and illumination detection function
- Sensing range setting (10 modes)
- left-right detection/partitions shielding
- KNX protocol

● Overview

The 4-partition human presence sensor employs 24GHz microwave detection technology. It is equipped with built-in motion sensors and luminance sensors, mainly used in lighting scenarios such as offices, hotels, or homes where there is a need for presence/motion detection, as well as environments related to luminance. The illuminance sensor can measure the current illuminance and not only supports conventional illuminance control functions but also has constant illuminance control function and human presence detection function. Additionally, the illuminance and motion detection functions can be flexibly combined for control. This sensor also integrates logical functions and scene group functions, enabling more complex and diverse demand control and application.

1. Parameters

Model	AX/F-CMPS.1	
Basic parameters	Communication method	KNX
	KNX bus working voltage	30VDC
	Auxiliary power input voltage	21-30VDC
	Auxiliary power supply current	≤50mA
	Auxiliary power consumption	≤1.2W
	transmitting frequency	24-24.25GHz
Function parameters	Motion sensing distance ^①	5.5m max
	Sensing distance	4m max
	Hanging height	<4m
	Delay time	10-3600s
	Illuminance value ^②	0-65535lux
Indicator light status	Power-on initialization	After power-on, the LED indicator light turns on and flashes for 10 seconds in red color. Then the LED indicator light goes off and the device enters the normal operating mode.
	Operating mode	When the sensor detects the presence of a person, the indicator light flashes once, and then sends a "person present" signal to the bus; after the delay period ends, it sends a "no person present" signal to the bus.
	Programming mode	Short press the programming button, the LED light remains red constantly, and the device is in programming mode.
Operating environment	Ta/Operation Temperature	-5 ~ +45°C
	Ts/Storage Temperature	-25 ~ +55°C
	Humidity Temperature	<95% No condensation
Wiring requirements	KNX bus terminal	φ0.8mm, Solid-core cable
Remark	<p>① The test range is based on the conditions where the sensor is hung at a height of 3 meters and the test is conducted in an indoor installation environment. The height of the test personnel is 170 centimeters, their weight ranges from 65 to 75 kilograms, and their walking speed is 1 meter per second. It should be noted that the installation in different scenarios may cause variations in the range, and the specific range should be based on the actual test results.</p> <p>② Given the spectral characteristics of the photosensitive devices, the test of illuminance values is uniformly conducted under natural light conditions.</p>	

2. Partition Function Description

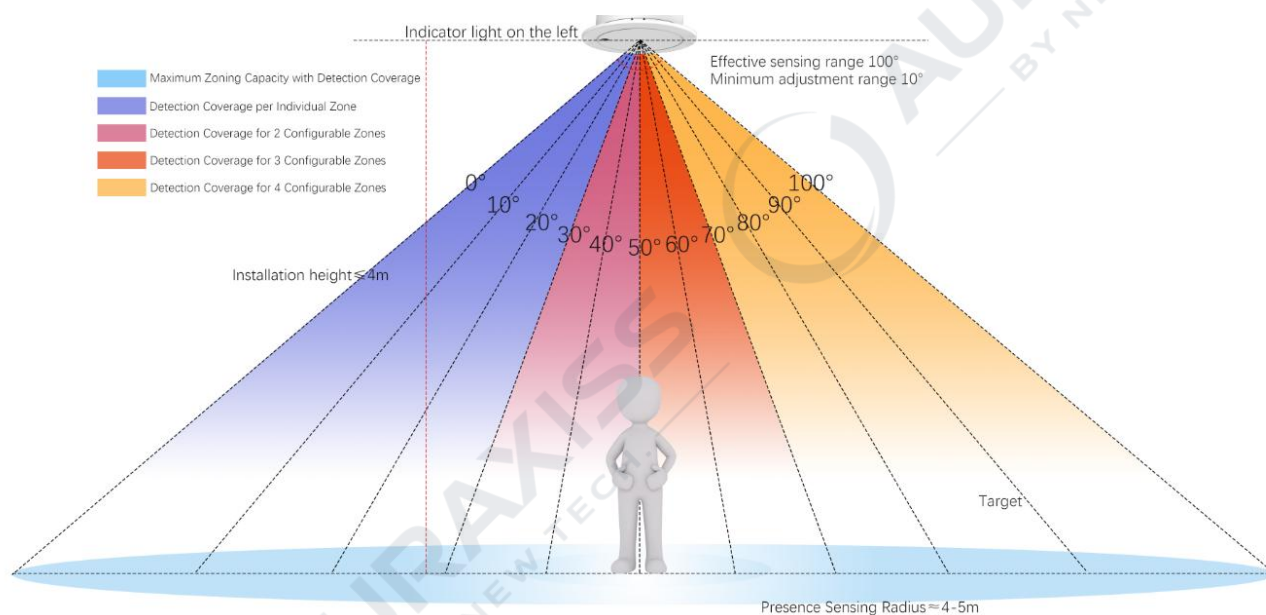

The 4-zone human presence sensor adopts a multi-sector radar array design, achieving a coverage range of $0-100^\circ$ through four independent zones. Each zone is equipped with an independent signal processing unit and has a dynamic boundary calibration function for detection accuracy.

3. Detection Diagram

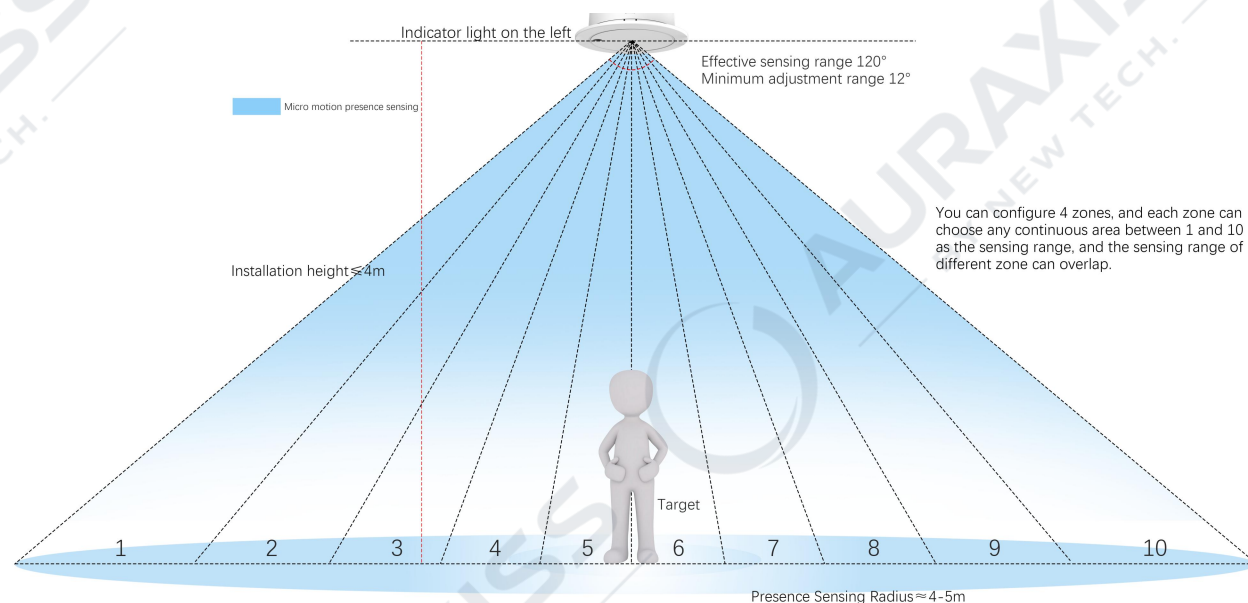

Each partition supports 10 degrees of angle adjustment for sensing, allowing users to precisely adjust the detection area according to the installation environment. By adjusting the detection cone angle of the radar sensor, the monitoring range can be effectively controlled, avoiding false triggering or creating blind spots.

4. Dimension

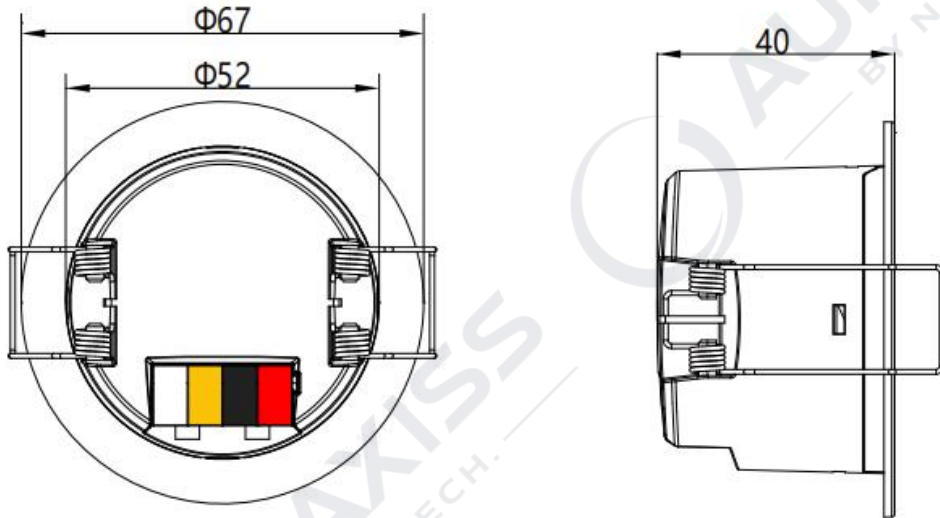

Dimension tolerance: ± 0.2 / Unit: mm

5. Pin and Button Instructions

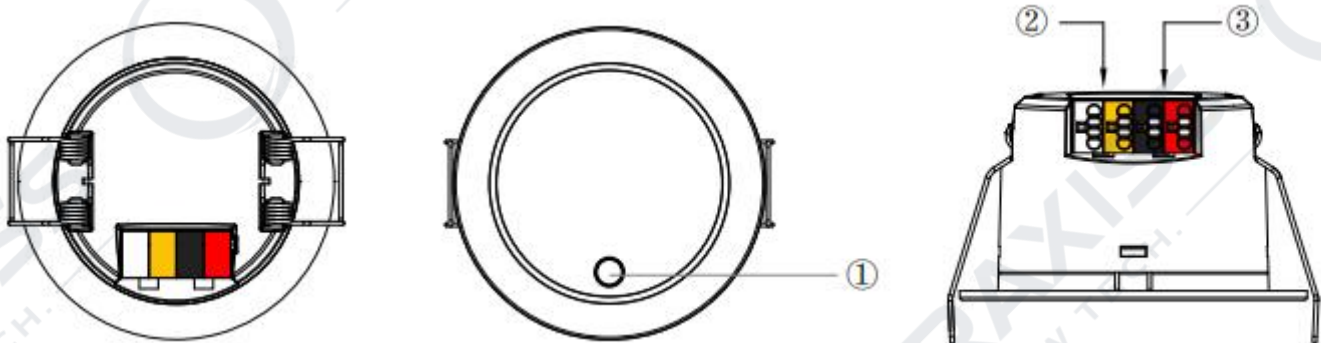

Pin	Description
Button	Short press to enter programming mode
Yellow	Auxiliary power supply +
White	Auxiliary power supply -
Red	KNX +
Black	KNX -

- ①: Illuminance sensor and integrated programming button
 LED light flashing green: radar has detected the presence of a person
 LED light remains red constantly: device is in programming mode
 ②: 21-30V auxiliary power supply terminal
 ③: KNX bus connection terminal

6. Wiring Diagram

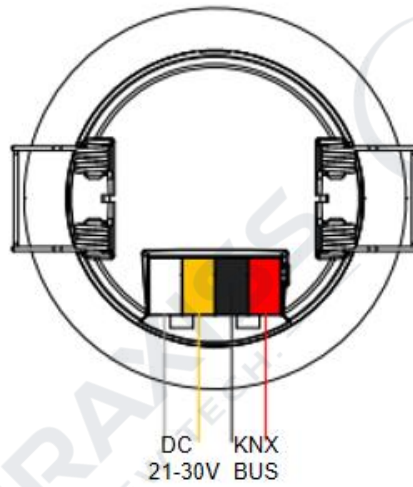

7. Installation Diagram

① Drill holes in the ceiling and reserve wires

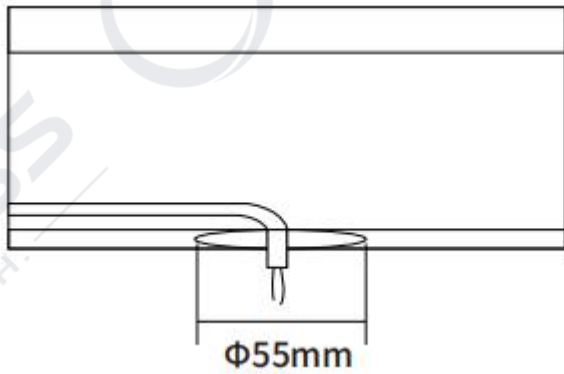

② Connecting the device to the wires

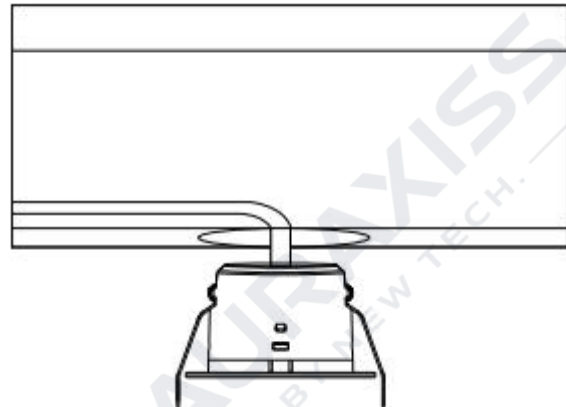

③ Adjust the installation snap-on clips

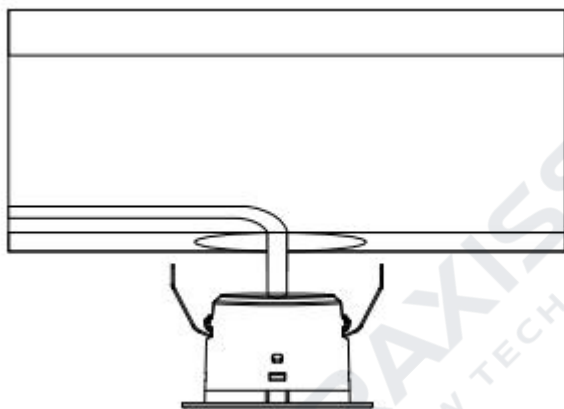

④ Embedded and fixed, installation completed

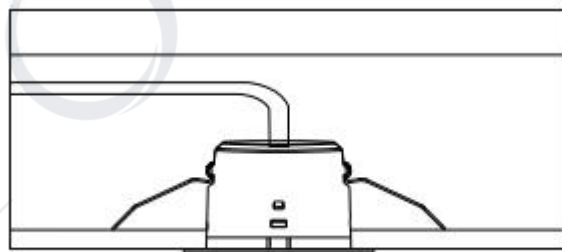

8. Function Description

Illumination function open



1. When there is sufficient ambient light, the sensor detects the movement of an object, but the light will not automatically turn on.
2. When the ambient light is insufficient, the sensor detects the movement of an object and the light automatically turns on.
3. When the moving object leaves and the preset time is over, the light will automatically turn off.

Illumination function close



1. When the sensor detects a moving object, the light automatically turns on and enters the delay time setup mode.
2. After the delay time has elapsed and the sensor fails to detect any moving objects, the light goes out.

9. Revision History

DATE	REV	Modification details
2025-10-14	V1.0	Initial Release