



Mobile sensor  
AX/F-CMMS.1

### Functional Description

- Daytime and nighttime configuration mode
- Constant Lumen Output (CLO)
- Master and slave operation mode
- Full-automatic and Semi-automatic modes
- Logical function
- Scene Group Function

### Characteristics

- 5.8GHz human movement sensing function
- Illuminance sensing
- 4 different sensing ranges for adjustment
- KNX protocol

### ● Overview

The Mobile sensor employs 5.8GHz microwave detection technology, featuring an internal mobile sensor and brightness sensor. It is mainly used in the lighting field and is applicable to scenarios such as offices, hotels, or homes where detection of presence/movement is required, or those related to brightness adjustment. The illuminance sensor can precisely measure the current illuminance. It not only supports conventional illuminance control functions but also has a constant illuminance control function. Additionally, illuminance and movement detection can be flexibly combined for control. Moreover, this sensor integrates logical functions and scene group functions, enabling it to meet more complex and diverse control and application requirements.

## 1. Parameters

Model		AX/F-CMMS.1
Basic parameters	Communication method	KNX
	KNX bus working voltage	30VDC
	Auxiliary power input voltage	21-30VDC
	Auxiliary power supply current	<100mA
	Auxiliary power consumption	≤1W
Output parameters	transmitting frequency	5730-5830MHz
	Transmission power	1dBm
Function parameters	Motion sensing distance <sup>①</sup>	6m max
	Hanging height	<4m
	Delay time	Adjustable
	Illuminance value <sup>②</sup>	0-65535lux
Indicator light status	Power-on initialization	The green indicator light remains on for 5 seconds before going out, indicating that the initialization is complete. The sensor enters an unmanned state, and at the same time, the KNX system enters the setup mode.
	Operating mode	If the sensor detects movement of a human body, the green indicator light will flash once and send a "person present" signal to the bus; when the person leaves, the delay period ends and a "person absent" signal is sent to the bus immediately.
Operating environment	Ta/Operation Temperature	-5 ~ +45°C
	Ts/Storage Temperature	-25 ~ +55°C
	Humidity Temperature	<95% No condensation
Wiring requirements	KNX bus terminal	φ0.8mm, Solid-core cable
Remark	<p>① The test range is based on the conditions where the sensor is hung at a height of 3 meters and the test is conducted in an indoor installation environment. The height of the test personnel is 170 centimeters, their weight ranges from 65 to 75 kilograms, and their walking speed is 1 meter per second. It should be noted that the installation in different scenarios may cause variations in the range, and the specific range should be based on the actual test results.</p> <p>② Given the spectral characteristics of the photosensitive devices, the test of illuminance values is uniformly conducted under natural light conditions.</p>	

## 2. Detection Diagram

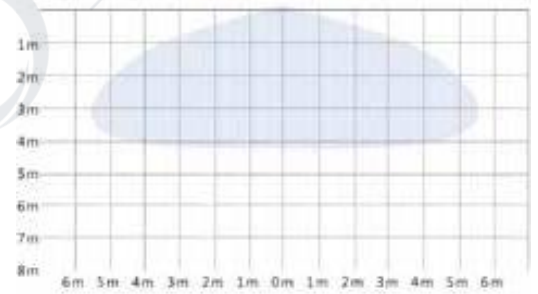
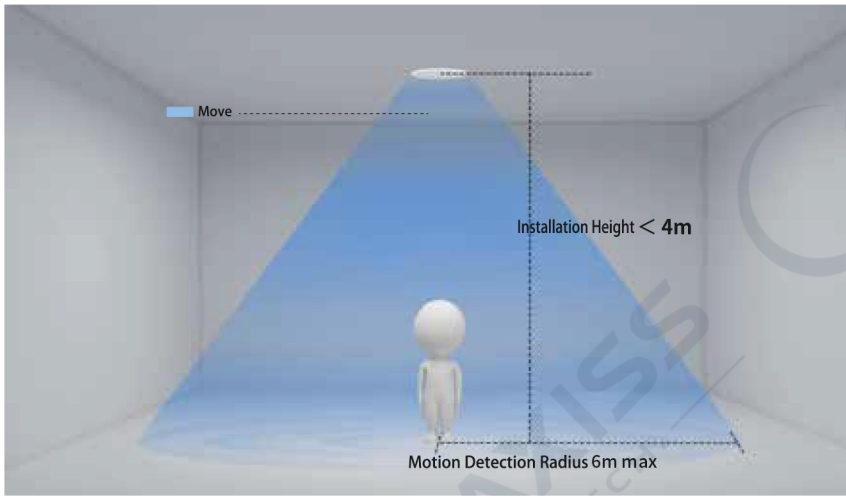

Motion sensing distance 6m max

## 3. Dimension

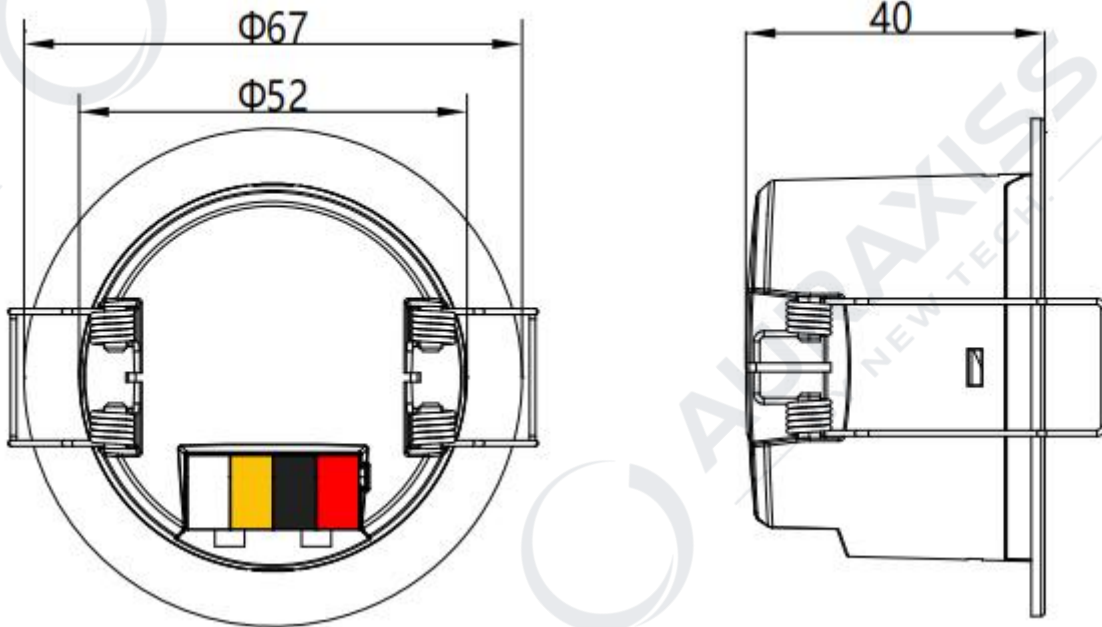

Dimension tolerance:  $\pm 0.2$  / Unit: mm

## 4. Pin and Button Instructions

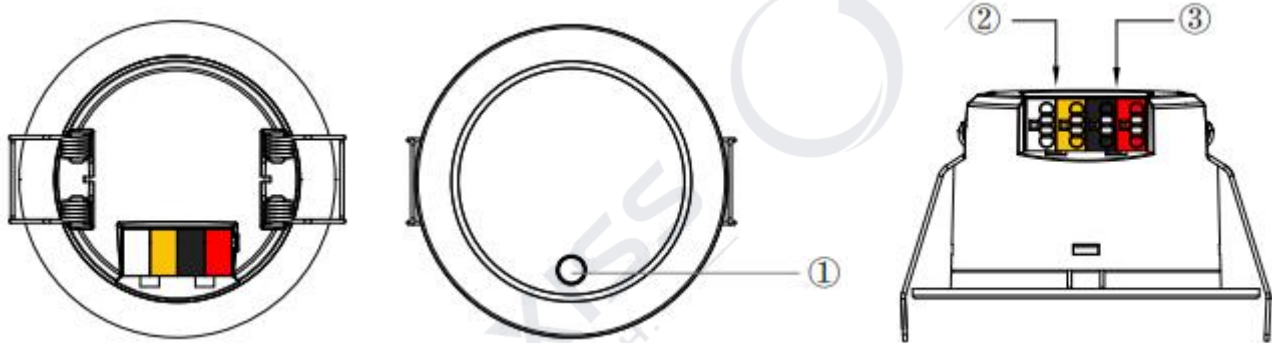

Pin	Description
Button	Short press to enter programming mode
Yellow	Auxiliary power supply +
White	Auxiliary power supply -
Red	KNX +
Black	KNX -

## 5. Wiring Diagram

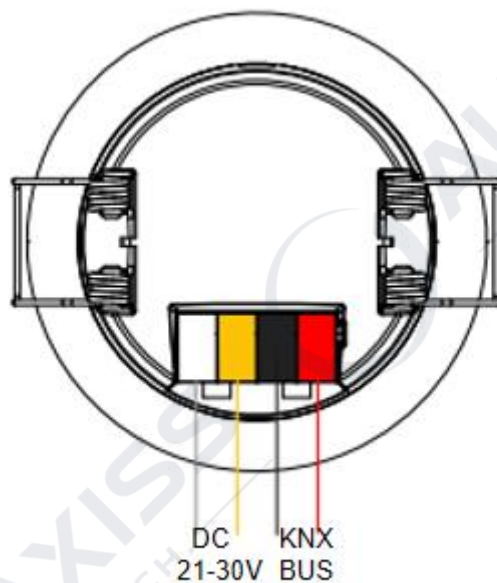

## 6. Installation Diagram

① Drill holes in the ceiling and reserve wires

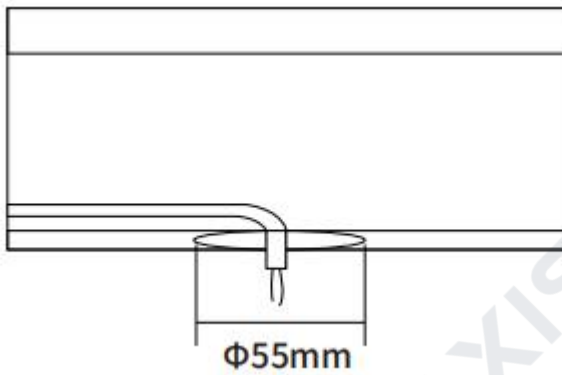

② Connecting the device to the wires

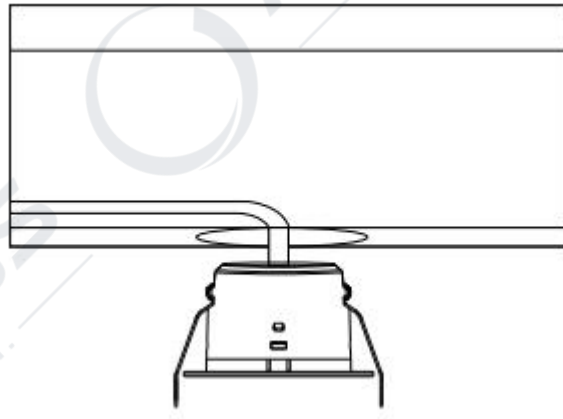

③ Adjust the installation snap-on clips

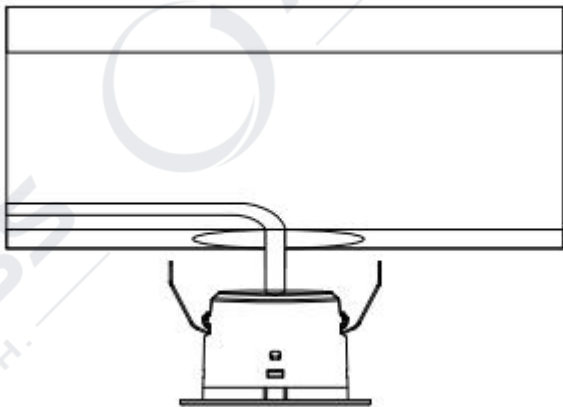

④ Embedded and fixed, installation completed

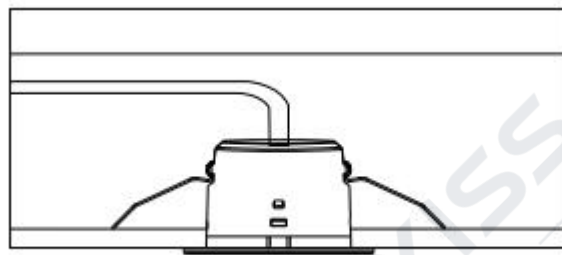

## 7. Function Description



1. When the sensor detects a moving object, the light automatically turns on and enters the delay time setting mode.
2. After the delay time has elapsed and the sensor fails to detect any moving objects, the light goes out.

## 8. Revision History

DATE	REV	Modification details
2025-10-14	V1.0	Initial Release